

BAKEOUT TENT



Bakeout tent assembled together with loadlock, transfer arm heating jacket and TecTra Bakeout heater fan.

TECHNICAL DESCRIPTION

The bakeout tents are a custom designed product, and can be built up like an oven around the bakeable components. The tent is very easy to install, and takes a minimum of space during storage. The tent parts are fixed together with VELCRO-fastener. Material-choice can be made to meet cleanroom requirement.

Recommended max bakeout temp.	Silicone coated glassfibre fabric:	220 degr. C
	Teflon coated glassfibre fabric:	220 degr. C
	Glassfibre fabric:	500 degr. C
Thickness:	7, 13, 21 and 28mm	
Insulation:	Nomex aramide fibres or glassfiber type E/C	
Thermal conductivity:	200 degr.C : 0,055 W/mk	
	300 degr.C : 0,075 W/mk	
Fastening:	By VELCRO or hooks	
General:	All material used, has been analysed and are approved acc. to health regulations.	

HEMI HEATING AB
P.O. BOX 2077,
S-151 02 SÖDERTÄLJE-SWEDEN

PHONE: +46 8 554 23250
FAX: +46 8 554 23255
www.hemiheating.se

bank giro
5333-6780
info@hemiheating.se

org. no.
556420-7586



As an additional accessory, the tent can be supplied with a supporting frame, made of rounded Al-profiles

HEMI HEATING AB
P.O. BOX 2077,
S-151 02 SÖDERTÄLJE-SWEDEN

PHONE: +46 8 554 23250
FAX: +46 8 554 23255
www.hemiheating.se

bank giro
5333-6780
info@hemiheating.se

org. no.
556420-7586



Standby Heater Fan

The tectra Standby Heater Fan is a unique heater device for baking UHV systems.

- 2.5 kW heating power
- 200 m³/h air circulation
- thermocouple control as standard
- saves bench space as it's part of the tent or box

The 2.5 kW heater power and the fan with 200 m³/h air circulation ensures a powerful yet even bakeout of a vacuum system. Standard feature is a temperature controller allowing a pre-set temperature in the range of 50 ° to 250 °C for optimum protection of sensitive instruments, Viton® sealed valves etc.. Units available for 240V/50Hz.

Free standing design to be mounted onto or under system table. When not in use it can be taken away saving valuable bench space. Design optimised to be used with bakeout tents, but also easily usable also with bakeout boxes.

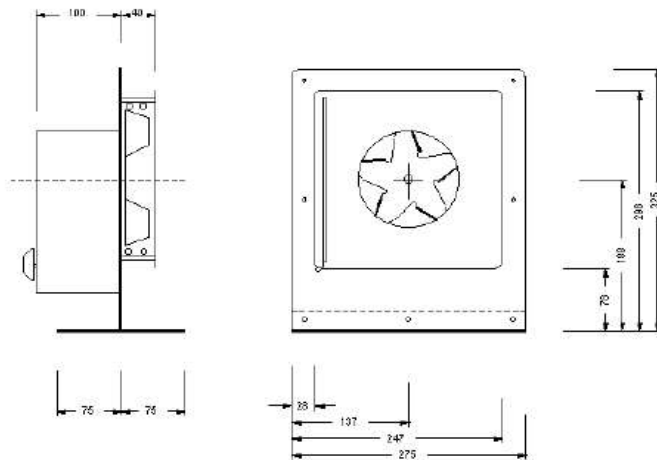

Further information: www.tectra.de/bakeout.htm



tectra GmbH
Physikalische Instrumente

Reuterweg 65
60323 Frankfurt/M
www.tectra.de

☎ 069-720040
Fax 069-720400
info@tectra.de

HEMI HEATING AB
P.O. BOX 2077,
S-151 02 SÖDERTÄLJE-SWEDEN

PHONE: +46 8 554 23250
FAX: +46 8 554 23255
www.hemiheating.se

bank giro
5333-6780
info@hemiheating.se

org. no.
556420-7586